

### CERTIFICARE

ISO 9001



### CARACTERISTICI

- Protectie IP65
- Interfata usoara
- Display 65x128pixel
- Protectie presiune cu iluminare rapida
- Unelte: viteza masurare, presiune ulei, temperatura, combustibil, baterie, ore de lucru, service
- Protectie presiune apa cu afisare pe display
- Schimbare limba afisata, 5 variante
- Start/Stop de la cheie
- Control al distanta cu GSM
- 10 Log-uri inregistrare

### FACILITATI

- 6 indicatoare led
- Racorire automata
- Programare Start/Stop
- Programare unitati de masura
- Programare unelte panou RS232
- Autonomie
- Programare usoara si completa
- Design compact

### INFORMATII TEHNICE

- Carcasa ABS, protectie UV 215x200x140mm
- Iluminare buton pentru protectie presiune
- Cheie aprindere
- Presiune 0-16 bar
- Protectie pomp 4mt
- Panou R51MP

### CODURI

R51MP012 : 12Vdc  
R51MP024 : 24Vdc



+70 C°



-20 C°

### DISPLAY: Masuratori si parametri

- Masurarea continua apa
- Rata presiune apa
- Presiune minima apa
- Presiune maxima apa
- RPM
- Presiune ulei
- Temperatura panou
- Nivel combustibil

### DATE TEHNICE

- Temperatura lucru: -20  
+ 70 grade C
- Temperatura depozitare -30  
+80 grade C
- Voltaj alimentare 8-35 Vdc
- Display 128x64
- Standarde: EN61010
- Protectie IP65
- Dimensiuni: 109 (O), 72mm  
adancime
- Intrerupere: 99 mm (O)

- Autonomie
- Voltaj baterie
- Ore de lucru
- Ore pana la terminare
- Ore pana la urmatoarea  
utilizare
- Ore pana la service baterie
- Icon alarma

### INDICATOR LED

- Alarma incarcare baterie
- Alarma pompa apa
- Temperatura maxima
- Nivel scazut combustibil
- Nivel scazut ulei
- Alarma generala

### BUTOANE

- Navigare cu 2 butoane

### LISTA ALARME

- STOP
- START
- Service
- Baterie
- Alternator baterie
- Lichid racire
- Utilizator
- Primul service
- Defectiuni presiune ulei
- Defectiuni scurgeri
- Defectiuni Start
- Defectiuni mecatine
- Temperatura

- Nivel scazut combustibil
- Nivel scazut ulei
- Nivel crescut baterie
- Nivel scazut baterie
- Nivel ridicat presiune apa
- Nivel scazut presiune apa
- Nivel scazut RPM
- Nivel crescut RPM

### SCHITA PARTE ELECTRICA

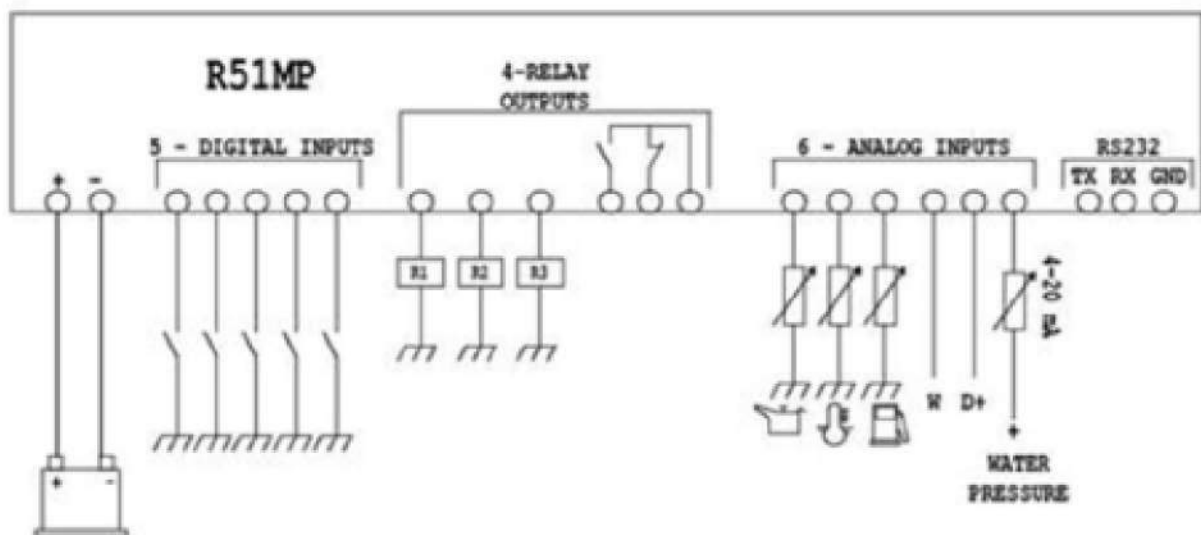

Tel: +40 21-369 1340  
Fax: +40 21-369 1341  
Mobil: +40 749 996 666  
+40 744 671 621

E-mail:  
contact@tecnoelettra.ro  
office@mecanexim.ro  
office@betamarine.ro  
Web:  
www.tecnoelettra.ro  
www.mecanexim.ro  
www.betamarine.ro